

ACCURATE GAS FLOW TRACKING & MONITORING IN ONE DEVICE

The Gas Tracker™ Digital Gas Flow Monitor provides an easy way to monitor and track shielding gas flow in robotic or semi-automatic MIG or TIG welding applications. The Gas Tracker™ is two monitors in one – it may be used as a portable unit or mounted in-line. It provides a simple and accurate method for monitoring and totalizing incoming gas flow, or measurement and verification of gas flow at the nozzle.

- ▶ **PORTABLE APPLICATION:** Check and verify gas flow at the nozzle to avoid porosity and other serious weld quality issues. Each monitor includes a hose, nozzle cup and filter assembly that fits all standard nozzle sizes, along with a rechargeable li-ion battery that lasts up to 24 hours.
- ▶ **IN-LINE APPLICATION:** The monitor can function as a gas totalizer, verify proper gas flow and keep a record of average gas flow per weld (data downloadable via USB connection).
- ▶ Accurate digital gas flow reading (+/- 3%) allows optimization of flow rates for consistent weld quality and eliminating excess gas usage
- ▶ Touchscreen interface with digitally displayed flow rate of 0 – 100 CFH (0 – 50 LPM) with 1 CFH resolution, viewable in Imperial or Metric units
- ▶ PLC connectivity allows automated alert functions
- ▶ Pre-calibrated for a variety of gas mixture options to cover most welding applications (see sensor specifications)
- ▶ 1-year limited warranty



IN-LINE APPLICATION



PORTABLE APPLICATION

SOFTWARE FEATURES

- ▶ View and export time-stamped gas flow data (per weld), including duration of flow, gas flow rate (in CFH or LPM), gas consumed and gas remaining
- ▶ Edit or refill gas (if applicable)
- ▶ Quickly view the gas remaining
- ▶ Options for measurement units in Imperial (US) or Metric
- ▶ Ability to connect to multiple Gas Trackers at once

Chart and Gas Refill screen

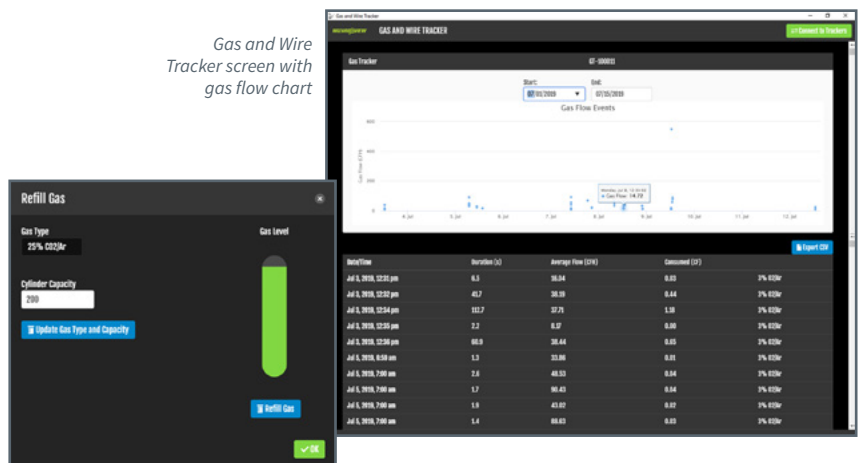

SPECIFICATIONS

HARDWARE

- ▶ Dimensions: 7" (178 mm) X 5.25" (134 mm) X 3.25" (83 mm)
- ▶ Weight: 2.2 lbs (1 kg)
- ▶ Input Power: 24 VDC
(Type A-style plug; 100 – 240 VAC required for power supply)
- ▶ Power Consumption: 2 A maximum
- ▶ 3.5" (89 mm) LED Touch Screen
- ▶ Internal memory for up to 8,000 events
- ▶ USB connection for exporting data via PC connection

DIMENSIONS

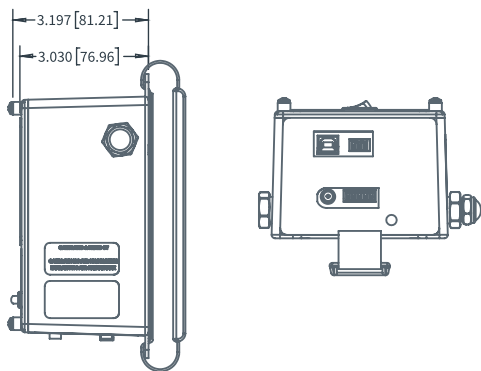
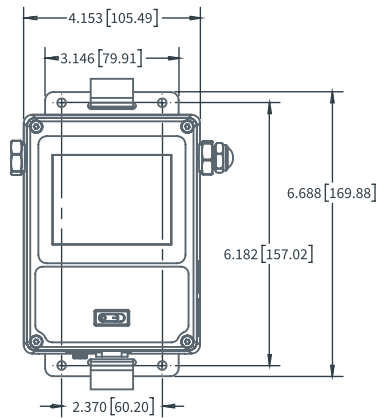

GAS FLOW SENSOR

- ▶ Range: 0 – 100 CFH (0 – 50 LPM)
- ▶ Accuracy: +/- 3% (Full Scale)
- ▶ Maximum Operating Pressure: 50 psi (350 kPa)
- ▶ Calibration Period: Yearly - Certificate of calibration included with each new unit
- ▶ Gas Types:
 - ▶ Argon (Ar)
 - ▶ Nitrogen (N)
 - ▶ Carbon Dioxide (CO₂)
 - ▶ Helium (He)
 - ▶ C-2 (98% Ar/2% CO₂)
 - ▶ C-10 (90% Ar/10% CO₂)
 - ▶ C-15 (85% Ar/15% CO₂)
 - ▶ C-20 (80% Ar/20% CO₂)
 - ▶ C-25 (75% Ar/25% CO₂)
 - ▶ 97-3 (97% Ar/3% O₂)
 - ▶ He-25 (25% He/75% Ar)
 - ▶ Trimix (90% He/7.5% Ar/2.5% CO₂)
- ▶ Not for use with flammable gases

SOFTWARE REQUIREMENTS

- ▶ Microsoft Windows 7 or newer with latest updates
- ▶ At least one (1) USB 2.0 or higher port
- ▶ At least 2 GB RAM
- ▶ 1 GB free disk space

Part No.	Description
WC-1-GS-S	Gas Tracker™ Digital Gas Flow Monitor — in-line or portable use for checking flow at the nozzle (includes gas fittings)
WC-1-GS-RECAL	Gas Tracker™ Digital Gas Flow Monitor Calibration Service (yearly recalibration recommended)